

Lumen Tech

Lighting, LLC.

Design QPA25
Designer Wall Pack
Maximum 400W Metal Halide
Or High Pressure Sodium

Specifications

Housing: Heavy duty cast aluminum with quick mount system. Powder coated finish. See finish note.

Lens: Prismatic borosilicate glass silicone sealed to door frame.

Reflector: Anodized aluminum, computer designed for efficiency.

Ballast: Pre-wired C.W.A., H.P.F. core and coil with capacitor.

Lamp: Clear mogul base.

Lamp Holder: High heat 4 K.V. rated, w/nickel plated copper screw shell, spring loaded center contact.

Finish: Bronze, detergent cleaned, prime coated chip resistant powder urethane polyester coating. Contact factory for other colors.

Photometric Information: Contact factory.

Labels: U/L listed suitable for wet location.

SPECIFICATIONS SUBJECT TO CHANGE WITHOUT NOTICE

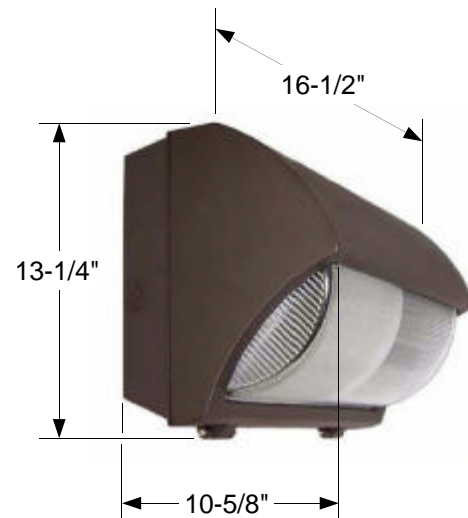

Ordering Information

Catalog Number	Watts	Light Source
QPA25250H	250	HPS
QPA25400H	400	HPS
QPA25250M	250	MH
QPA25250MP	250	MH Pulse Start
QPA25320MP	320	MH Pulse Start
QPA25350MP	350	MH Pulse Start
QPA25400M	400	MH
QPA25400MP	400	MH Pulse Start