

Lumen Tech

Lighting, LLC.

Design WP72
Surface Mount Wall Pack
Maximum 250 Watt Metal Halide
Or High Pressure Sodium

Specifications

Housing: Heavy duty cast aluminum. Bronze powder coated finish. See finish note.

Lens: High impact/heat resistant borosilicate glass refractor computer designed for wide distribution pattern, silicone sealed to door frame.

Reflector: Anodized aluminum, computer designed in conjunction with the lens for efficiency.

Ballast: Pre-wired C.W.A., H.P.F. core and coil with capacitor.

Lamp: Clear mogul base lamp (by others).

Lamp Holder: High heat 4 K.V. rated, w/nickel plated copper screw shell, spring loaded center contact.

Finish: Bronze, detergent cleaned, prime coated. Chip resistant powder urethane polyester coating.

Photometric Information: Contact factory.

Labels: U/L, CUL listed suitable for wet location.

SPECIFICATIONS SUBJECT TO CHANGE WITHOUT NOTICE

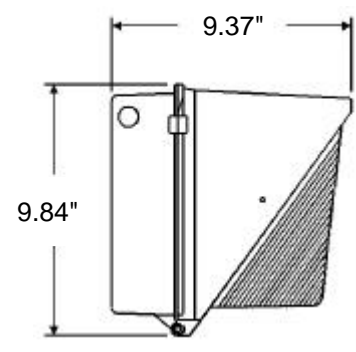

Ordering Information

Catalog Number	Watts	Light Source
WP72150H	150	HPS
WP72250H	250	HPS
WP72175M	175	MH
WP72250M	250	MH
WP72250MP	250	MH PS

Options & Accessories

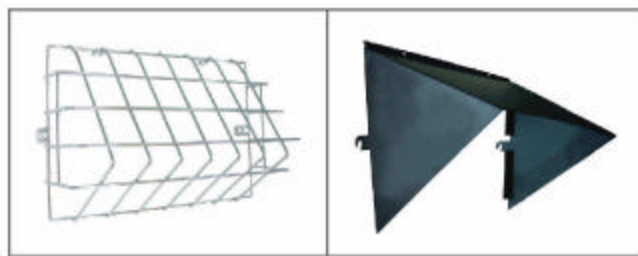

WP72WG Wire Guard

WP72VI Visor